

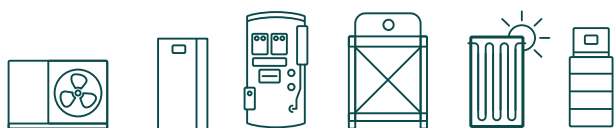

The heat-intelligent battery storage



NEW



Battery Storage Product Catalog

Since 1989, ÖkoFEN has been a specialist and pioneer in modern, efficient heating with environmentally friendly and renewable energy.

In 1997, we introduced the first type-approved pellet heating system to the market. Today, we manufacture pellet boilers that generate electricity and heat pumps that intelligently manage and make the most of times with low-carbon electricity. From the very beginning, our ambition has been to lead in technology and new markets. That drive still motivates us today, just as it did back then.

Our 200,000 installed heating systems keep people warm in more than 20 countries. In addition, we export to future markets such as Asia, South and North America. This is warmth with a clear conscience.

Europe's specialist for green heating



ÖkoFEN
electric

With ÖkoFEN electric GmbH, a newly founded subsidiary of ÖkoFEN, we will offer electrical components such as innovative battery storage systems, inverters, energy management solutions, and accessories **directly to electrical professionals.**

This ensures that electricians can be 100% confident that in the home of tomorrow, everything communicates and operates together with maximum efficiency and intelligent heat management.

For homeowners, the interconnected communication and control of heat and electricity will become reality — all from a single provider with award-winning, comprehensive customer service and support across Europe.

This is how you achieve maximum energy independence for an economical and sustainable energy future.

With ÖkoFEN.

Visit us online: electric.oekofen.com

The ÖkoFEN holistic System

ÖkoFEN Battery Storage

- Compact storage solution from 7,7–30,7 kWh
- Lithium iron phosphate battery for maximum safety
- Intelligent charging and discharging with the ÖkoFEN GreenBOX® based on weather forecast & electricity market price
- EMS electronics & software – Made in Austria
- Backup power & black start capability
- Modular, expandable, and scalable

ÖkoFEN Hydraulics

- Hygienic domestic hot water preparation
- Power2heat: Intelligent electric cartridge control for utilizing PV surplus
- Power2plug: Volt-free contact for smart integration of additional consumers (e.g., pool pump, e-bike charging, etc.)



ÖkoFEN Heat Pump

- Intelligent heating & cooling with the ÖkoFEN GreenFOX® heat pump and the award-winning GreenMODE
- Efficient, ultra-quiet, environmentally friendly refrigerant R290
- Made in Austria

ÖkoFEN Charging Station

- Flexible activation & cost-effective charging with the ÖkoFEN Charging Station
- Bidirectional charging available as an option (depending on the vehicle)

ÖkoFEN App

- Clear visualization and control options for all components in the myPelletronic App 2.0
- Predictive maintenance function for proactive service planning



Heating accounts for 60–70% of a household's energy consumption. That's why it's crucial that key consumers (heat pump, electric car, etc.) communicate seamlessly, efficiently, and in perfect harmony — **especially during winter and transitional seasons.** Weather forecast, sun position, CO₂ data, and electricity tariff predictions all work together perfectly. The GreenBOX® enables up to 100 % PV self-consumption and guarantees maximum, heat-intelligent energy utilization at the lowest possible cost.

Florian Haslinger, ÖkoFEN Management, Innovations & Products

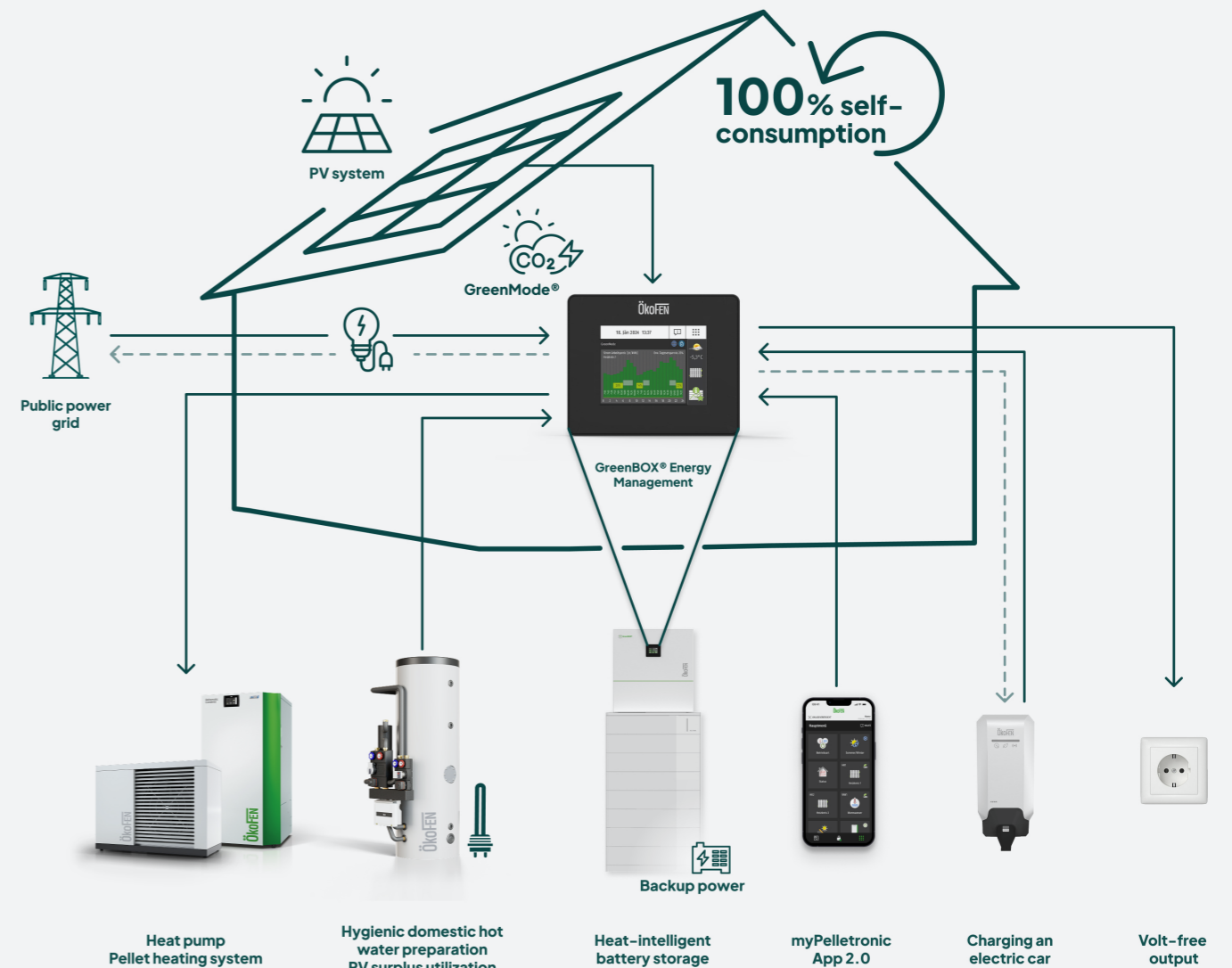

Advantages of the ÖkoFEN holistic System

- Perfectly coordinated components from ÖkoFEN
- Heat pump, pellet heating system, hydraulics, app, electronics & software – Made in Austria
- Centralized control and management of all key consumers in the system
- Smart PV surplus management with prioritization
- One app for heating, battery system, and EV charging station
- Best service network and local contacts

Battery Storage Overview

Perfectly combined with a pellet heating system or heat pump, the ÖkoFEN electric battery storage ensures **maximum independence** and the **lowest possible energy operating costs**.

- Heat-intelligent control and software from Upper Austria
- Electronic hardware from Upper Austria
- Server infrastructure and data management in Europe

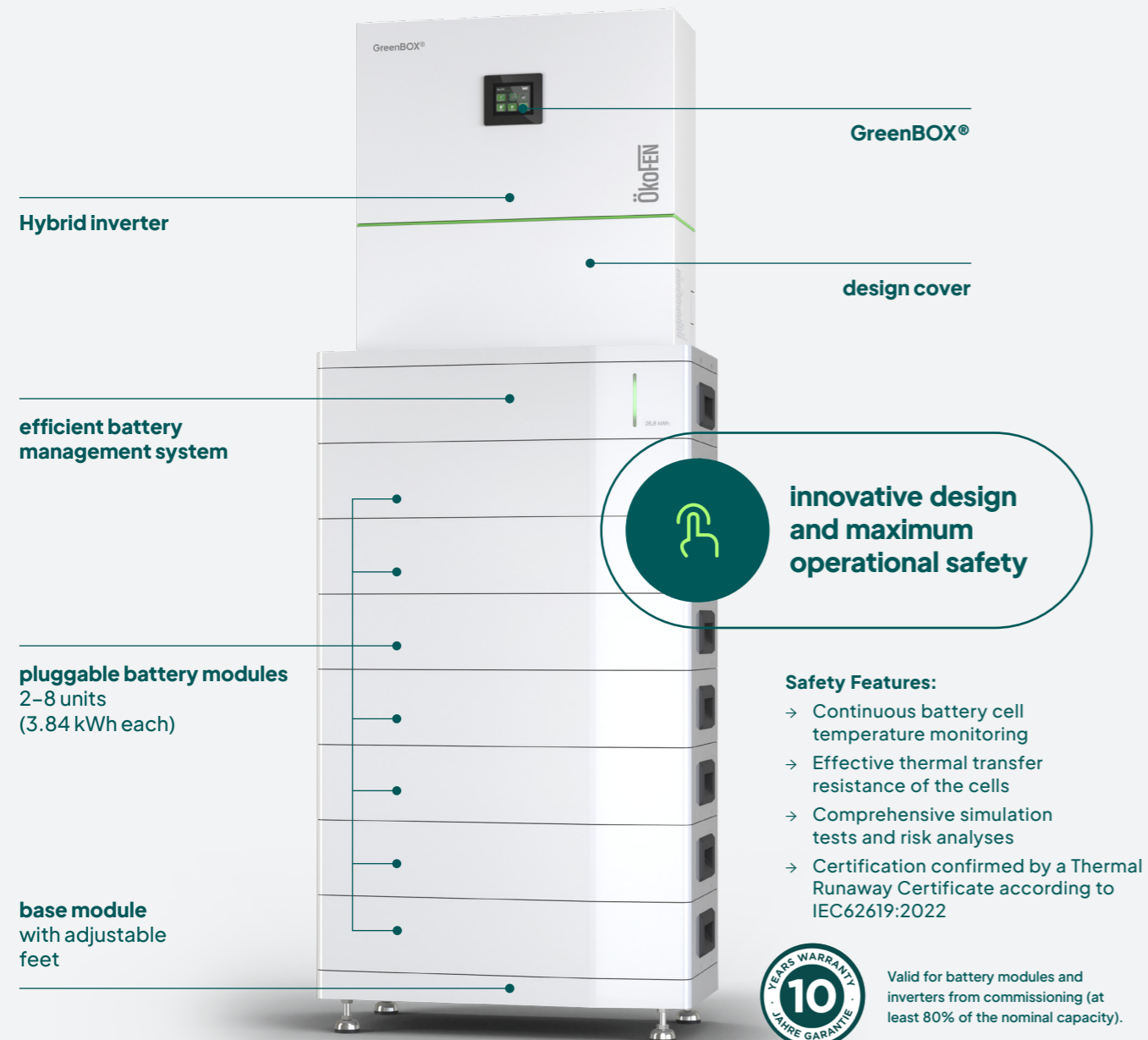

Functions PLUG & PLAY

- Optimal charging & discharging control
- Communication with ÖkoFEN heating system
- myPelletronic App for monitoring and control
- Blackout and black-start capability
- Online weather data with solar power forecast
- GreenMode for processing dynamic electricity tariffs including forecast

- Seamlessly integrates into any existing PV system.
- Ideal for combination with ÖkoFEN heat pump & pellet heating system.

Home storage cell technology

- LFP Lithium Iron Phosphate** Small, safe, affordable, long lifespan, no cobalt
- NMC Nickel Manganese Cobalt** Even smaller, thermally less stable, shorter lifespan
- Lead-Acid** Sensitive to deep discharge, fewer cycles, shorter lifespan
- Sodium-based** Large size, lower cycle stability
- Redox-Flow** Large size, high investment costs

Practical savings during transitional seasons

In general, PV yield is high in summer and low in winter. Looking at electricity consumption in the months of March, April, September, and October, the heat-intelligent battery system can reduce grid dependency by up to 76%, depending on its size and configuration.

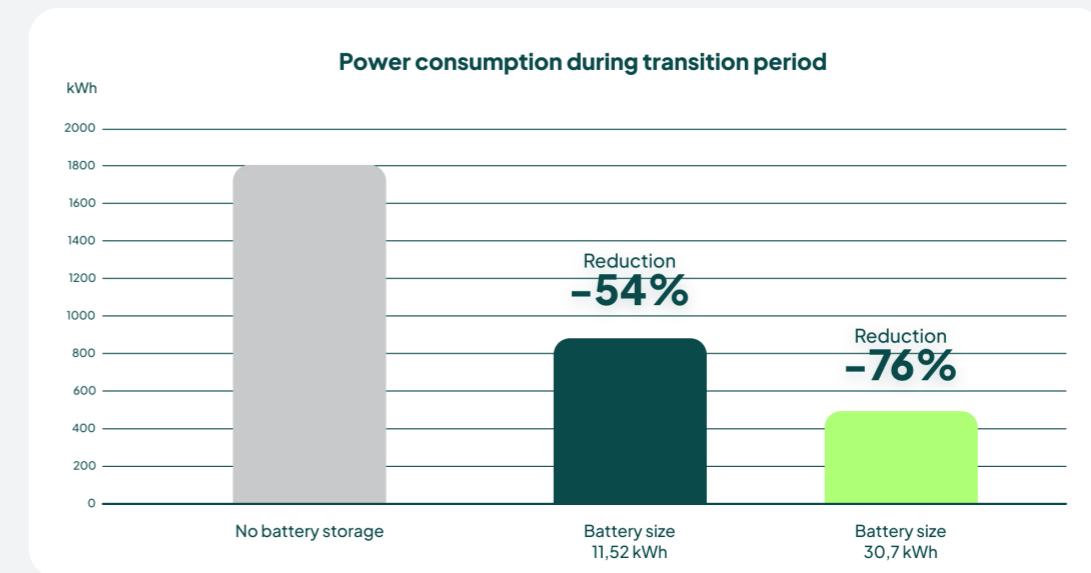

Assumption: 10 kWp PV system, south-facing, tilt angle 20°, Household electricity: 3,000 kWh, Heat pump: 165 m² living area – 6,000 kWh consumption, Domestic hot water with HP, Indoor temperature: 22.5 °C, Source: energieins-titut.at/tools/susi – 28.05.2025, Months considered: March, April, September, October



Power specifications

	Standard		with heat pump or electric vehicle		with heat pump and electric vehicle		
Battery modules	2	3	4	5	6	7	8
Storage capacity (kWh)	7,7	11,5	15,3	19,2	23	26,8	30,7
Maximum usable storage capacity (kWh)	6,9	10,4	13,8	17,3	20,7	24,1	27,6
Nominal voltage (V)	153	230	307	384	460	537	614
Charge and discharge power	3,8-6,1	5,8-9,2	6,0-12,3	6,0-15,4	6,0-18,4	6,0-20,0	6,0-20,0
Dimensions in mm (698 x 356 x H) including BMS and inverter	1.117	1.255	1.393	1.531	1.669	1.807	1.945
Weight (kg)	159	201	243	285	327	369	411

*Maximum depth of discharge: 90% DOD

Hybrid inverter	6 kW- 3P-3G25	8 kW- 3P-3G25	10 kW- 3P-3G40	12 kW- 3P-3G40	15 kW- 3P-3G40	20 kW- 3P-3G40
Maximum usable DC input power (kWp)	9	12	15	18	22,5	30
Dimensions without battery in mm (W x D x H)	698 x 356 x 613					
Maximum AC output power (kW)	6,6	8,8	11,0	13,2	16,5	22
Maximum DC input voltage (V)	950					
MPPT voltage range (V)	120-950		200-950			
Minimum DC start voltage (V)	135					
Maximum DC start voltage (V)	950					
MPP tracker / string connections per MPPT	2 / 1		2 / 2			
Nominal current per MPPT	15		30			
Maximum DC charge and discharge current (A)	25		40			
Maximum DC charge and discharge power (kW)	6,0	8,0	10,0	12,0	15,0	20,0
Emergency power switchover time	< 10 mS					
Weight (kg)	55		59		62	



CO₂ balance: production & transport of battery storage system

10 kW inverter & 15.36 kWh battery incl. BMS ~ 2.072 kg CO₂e
 Increase in PV self-consumption from 25% to 70% saves ~ 425 kg CO₂e/a
CO₂ payback period 4,87 years

Assumption: Household electricity consumption: 4,000 kWh, Heat pump heating consumption: 4,000 kWh, Additional EV with annual consumption of 2,500 kWh (approx. 15,000 km), Average CO₂ per kWh in Austria and PV: 20 g CO₂e, Average CO₂ per kWh in Austria: 110 g CO₂e *A diesel car emits approx. 2,100 kg CO₂e per year at 15,000 km
 Calculation: ÖkoFEN, 06/2025

Energy Management

GreenBOX®

The ÖkoFEN GreenBOX® intelligently connects all main electrical consumers together.



Advantages of the GreenBOX®

- Maximum self-consumption of solar power and reduction of electricity costs
- Predictive charging and discharging of the battery based on electricity tariffs and weather forecasts
- Maximum independence and highest degree of autonomy
- Maximum safety in case of blackout
- Smart networking of all energy consumers and producers in the system
- Maximum flexibility through expandability
- Easy and quick installation
- Continuous development & no subscription costs for software, etc.
- All-in-one device: storage, battery management, energy meter
- Self-explanatory thanks to the simplest operation
- Software & system architecture developed in Austria
- 10-year battery warranty from commissioning (at least 80% of the nominal capacity)

GreenBOX® – Example day in March

The ÖkoFEN GreenBOX® enables grid-friendly feed-in, reduces grid consumption, and loading cycles.

10 kWp PV system + 15 kWh battery storage
No dynamic tariff

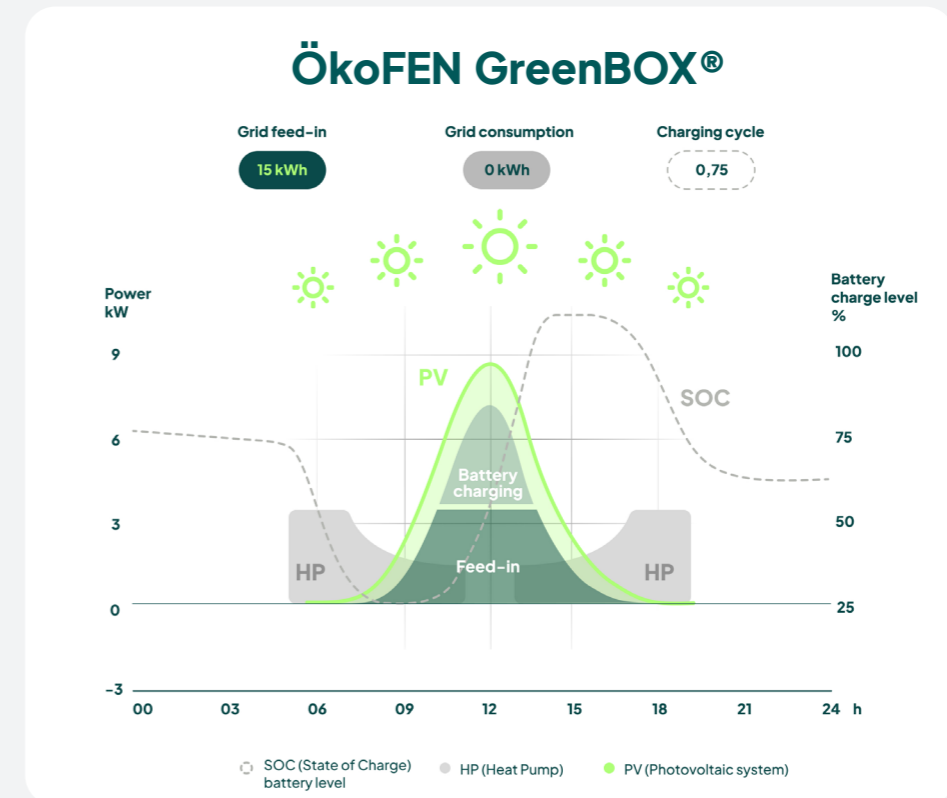

Includes feed-in optimization, heat-intelligent GreenMode®, and EcoMode.

Source: ÖkoFEN customer Franz H., District Ried im Innkreis, practical value on March 19, 2025.

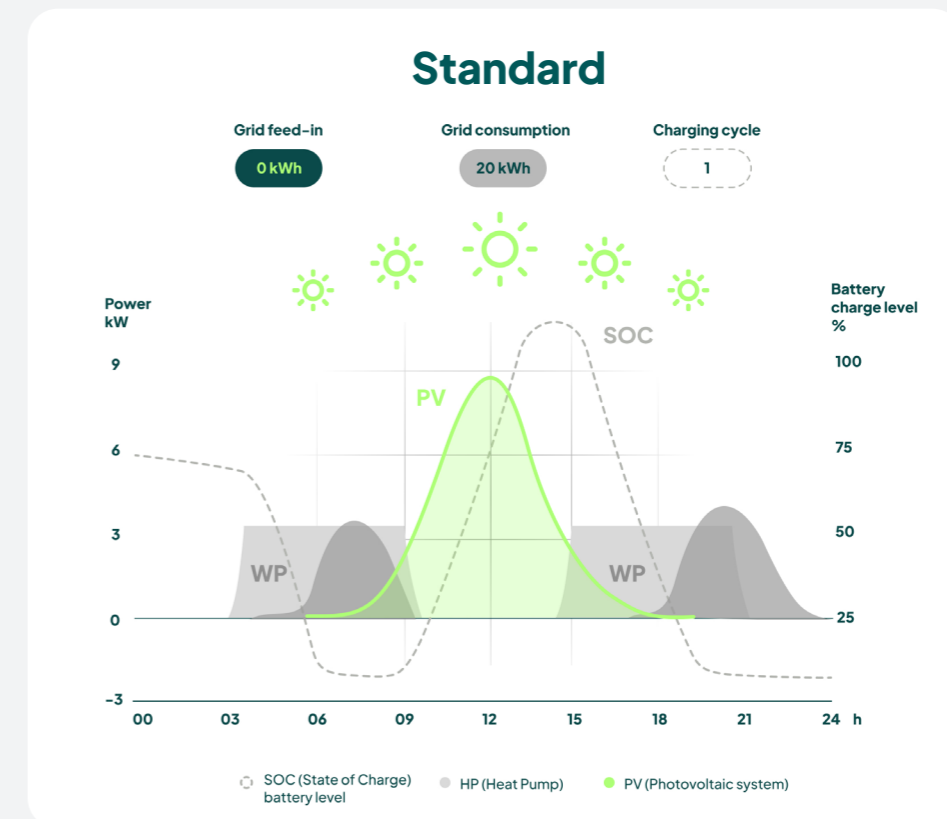



 **The ÖkoFEN GreenBOX® processes ALL dynamic electricity tariffs – independently of the grid provider.**

Example 1
To avoid high electricity costs during peak times, time-controlled discharging of the battery storage minimizes grid consumption, ensuring that the stored electricity is specifically used during periods of high electricity prices.

Example 2
When bad weather is forecast, the battery storage is charged overnight at a low cost and based on market electricity prices with the predicted amount of energy, while on sunny days, charging from the grid is omitted.

Example 3
Depending on the weather forecast, on sunny days the battery charging is slowed down or delayed to distribute feed-in as evenly as possible throughout the day, since on these days the battery charging is guaranteed anyway.

Settings

Grid-optimized feed-in:
The ÖkoFEN GreenBOX® reduces the load on the power grid during maximum feed-in.

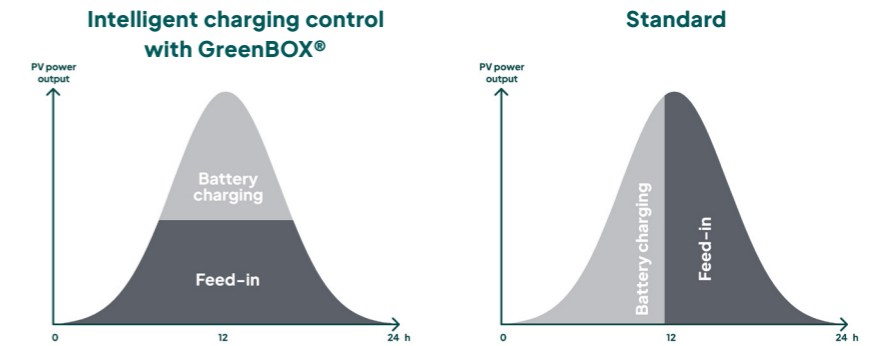

Selectable Scenarios

PV Yield

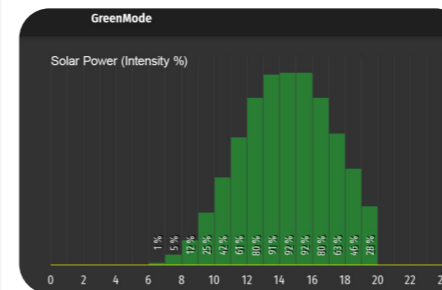

PV-optimized

- Active charging and heat-intelligent discharging based on PV yield and current real-time electricity consumption
- Option: Charge EV with surplus energy

Time Program

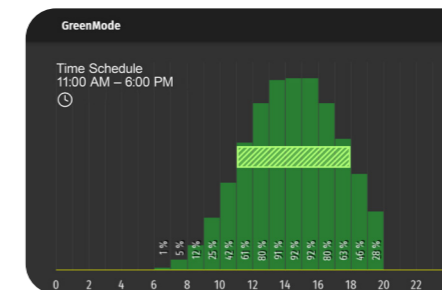

Scheduled Charging

- Active charging and heat-intelligent discharging based on PV yield AND manual charging to a set value at a desired time
- with an adjustable maximum charging power (up to inverter capacity)
- Outside the defined time window, the battery will not be charged

Price-Optimized Charging



Price-Optimized Charging

- Active charging and heat-intelligent discharging based on PV yield AND automated charging to a set value depending on the current electricity price
- with an adjustable maximum charging power (up to inverter capacity)

Intelligent Mode

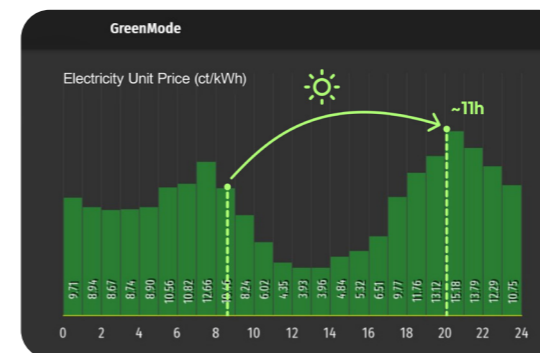

Automated, Smart Charging

- Active charging and heat-intelligent discharging based on expected PV yield, including intelligent, maximum possible feed-in
- Lowest-cost charging
- Integration of PV size, market-based electricity price, weather data, sun position, etc.
- AI software: self-learning and self-optimizing
- Software automatically scans until the next electricity price peak and adjusts the battery to a configurable SOC by then
- Flexible electricity tariff required
- Bidirectional discharge of an EV prepared – depending on model and grid provider

Changes to the software and visualization reserved. All representations are exemplary and may vary depending on the software version.



Visualization and Statistics

- Clear energy visualization
- Recording of all relevant data
- Statistical representation of all relevant data
- Status information

One app for heat and electricity



Energy visualization

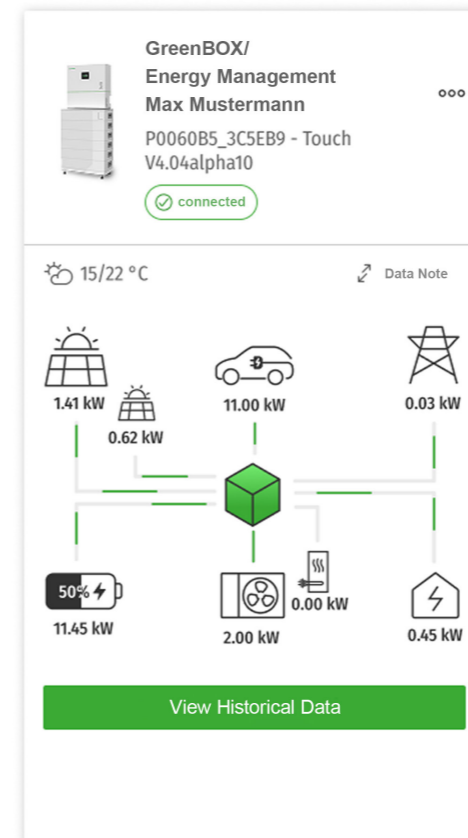

Data statistics

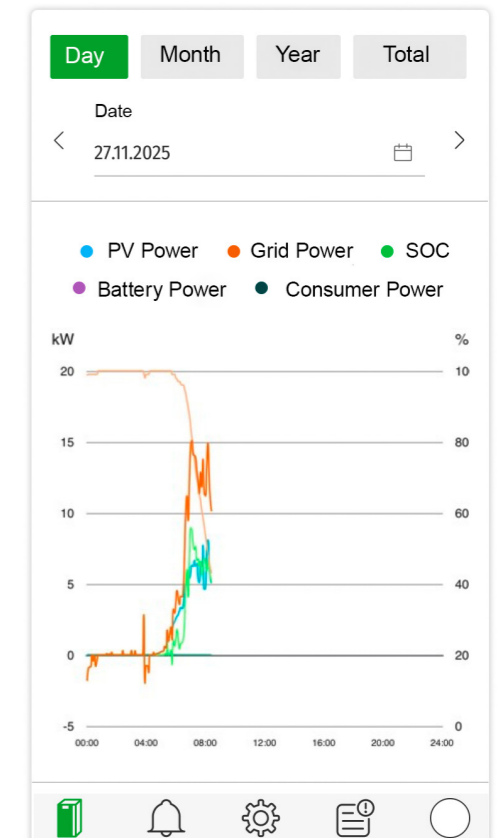

Installation

- Simple stacking without additional wiring
- Easy commissioning and operation
- Uniform touch-control components
- No additional interfaces to the heat pump or wallbox

Illustration showing 26.8 kWh including GreenBOX®

schematic illustration

1
New installation without GreenBOX® and without emergency power

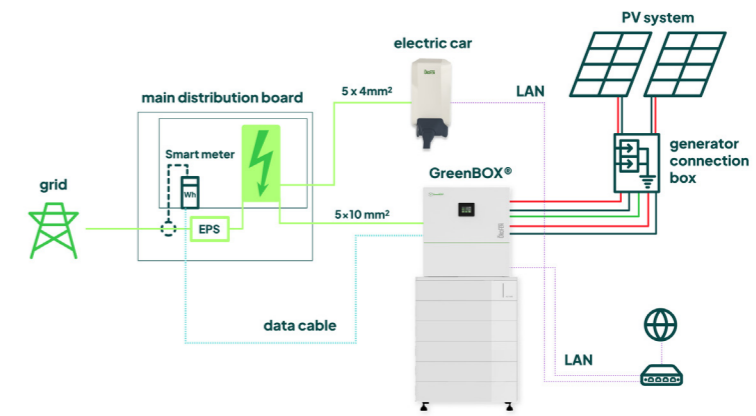

2
New installation including GreenBOX® and emergency power switching

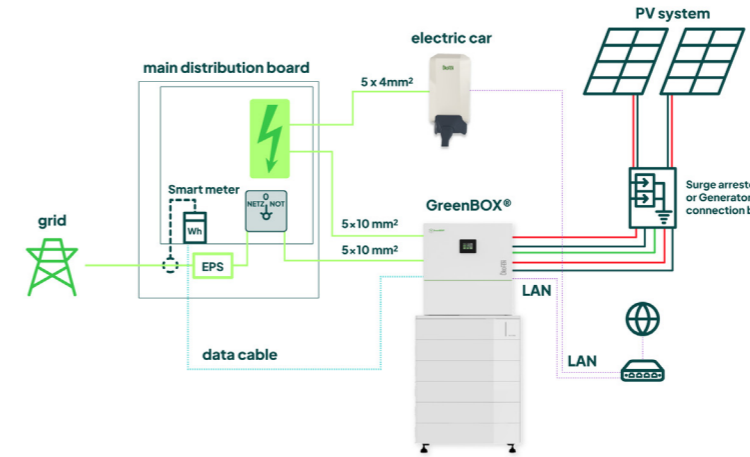

3
New installation in an existing building including GreenBOX® and emergency power switching

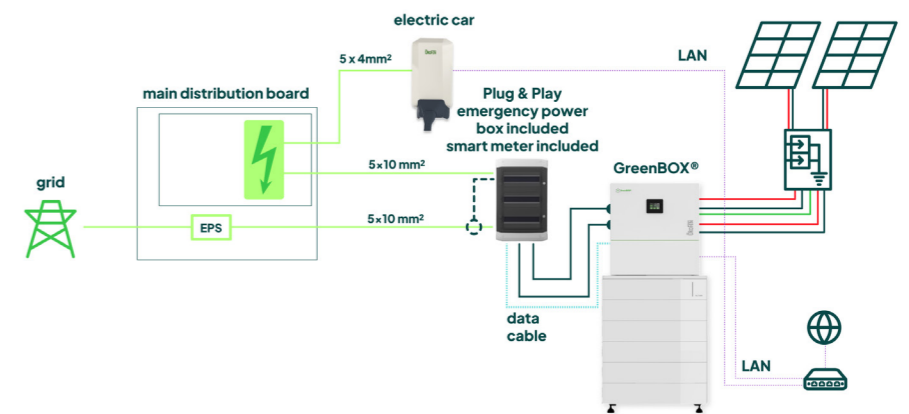

4
Installation combined with an existing system and existing inverter

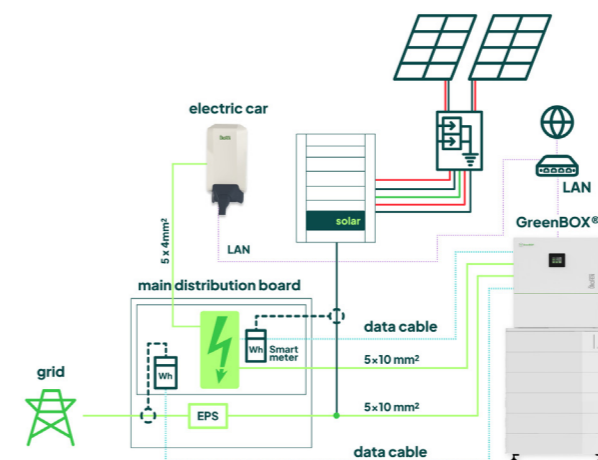

Technical Data

- Cell Technology: LiFePO₄
- Hybrid Inverter 10 kW – 3-phase: (W x D x H): 698 x 356 x 613 mm, 59 kg
- BMS: 698 x 356 x 138 mm, 11 kg
- Battery Module 3.84 kWh: 698 x 356 x 138 mm, 42 kg
- Base Module: 698 x 356 x 100 mm, 15 kg – incl. adjustable feet
- Total Storage System with 30.7 kWh (8 modules): 698 x 356 x 1945 mm
- Clearance to Ceiling: > 300 mm
- Enclosure Protection Rating: Inverter: IP65
- Enclosure Protection Rating: Battery Storage: IP21 (24 cells per module)

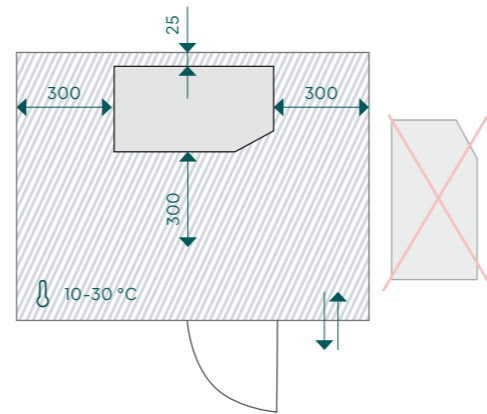

Gross capacity	Number of battery modules	Dimensions
7,7 kWh	2 pcs. LFP battery storage modules	698 x 356 x 1117 mm
11,5 kWh	3 pcs. LFP battery storage modules	698 x 356 x 1255 mm
15,3 kWh	4 pcs. LFP battery storage modules	698 x 356 x 1393 mm
19,2 kWh	5 pcs. LFP battery storage modules	698 x 356 x 1531 mm
23,0 kWh	6 pcs. LFP battery storage modules	698 x 356 x 1669 mm
26,8 kWh	7 pcs. LFP battery storage modules	698 x 356 x 1807 mm
30,7 kWh	8 pcs. LFP battery storage modules	698 x 356 x 1945 mm

Installation Site Information

- The inverter must be installed in a well-ventilated environment, as the device heats up during operation.
- The floor must be flat, level, and capable of supporting the product's weight.
- The optimal ambient temperature for the system is 10–30 °C. If this range is exceeded, performance will be reduced.
- Permissible installation temperature range: 5–35 °C.
- The installation environment must be free of dust and explosive substances.
- The system must not be installed in rooms with open flames or moisture.
- Maintain a distance of more than 2 m from external heat sources with high radiation temperatures (> 60 °C), such as stoves.
- Do not install the device in escape routes, staircases, bedrooms, or corridors, or in areas accessible to children or pets.
- For detailed information, consult your electrical specialist.

General Information

- Battery storage also available without ÖkoFEN heating system
- Inverter also available without battery storage
- ÖkoFEN inverter is mandatory – existing inverter can be used additionally (however, efficiency loss)
- Battery storage can also be cascaded
- Internet connection of the inverter is a warranty requirement
- Direct online sales to electrical trade professionals
- Installation and commissioning by electrical trade professionals
- Delivery within Europe – optionally to end customers or electrical trade professionals
- Storage capacity can be expanded within 2 years from commissioning
- ORDER – ONLINE ONLY – via: electric.oekofen.com
- SUPPORT – Mon–Thu 8:00–16:00, Fri 8:00–12:00 – via: electric.oekofen.com
- Safety certification according to IEC 62619:2022 including thermal runaway testing

Accessory

ÖkoFEN P40 Wallbox

Advantages

- Easy installation & setup
- 1-phase or 3-phase PV charging
- Integrated Type A residual current device
- Intelligent charging management
- Integrated energy meter
- WLAN/LAN communication & visualization
- Up to 11 kW charging power (optional 22 kW)
- Bidirectional integration – depending on model and grid provider (optional)
- Made in Austria



Scope of delivery: Charging station incl. mounting material, 6 m Type 2 charging cable, 1 RFID chip
Dimensions (H x W x D): 476 x 221 x 142 mm

Avoids complex installation at the main electrical distribution board



Flexible Emergency Power Box:

Emergency power box for operation during grid outage

Pre-installed box for manual switching to emergency power mode, incl. Energy Meter LAN
Dimensions (H x W x D): 500 mm x 300 mm x 200 mm

Learn more about the GreenFOX heat pump and hydraulics.





Durability
 ÖkoFEN quality guarantees
 reliable, long-lasting products

**98 %
 customer satisfaction**

**Smart control
 with touch display**

The ÖkoFEN Promise

**High efficiency
 and cost-effective operation**

**Innovative and always up to date
 with the latest technology**

**190,000 existing
 customers**

**Regional value
 creation**



**Heat-intelligent energy
 solutions & battery systems**
 ÖkoFEN electric GmbH
 Gewerbepark 1
 4133 Niederkappel
 electric@oekofen.com
 electric.oekofen.com

Available at your electrical specialist:

ÖkoFEN electric GmbH is part of the ÖkoFEN Group and operates completely independently in sales and service.